Unifactorial or Single Gene Disorders

Professor Hanan Hamamy
Department of Genetic Medicine and Development
Geneva University
Switzerland

Training Course in Sexual and Reproductive Health Research
Geneva 2015

Single gene = Unifactorial = Mendelian Disorders

- A single gene disease occurs due to a change in a gene that leads to loss or disturbed function of that gene.
 - There are thousands of different single gene disorders, most of them are individually rare.
 - Examples of common gene disorders are sickle cell anemia and cystic fibrosis.
-

UNIFACTORIAL OR SINGLE GENE DISORDERS comprise

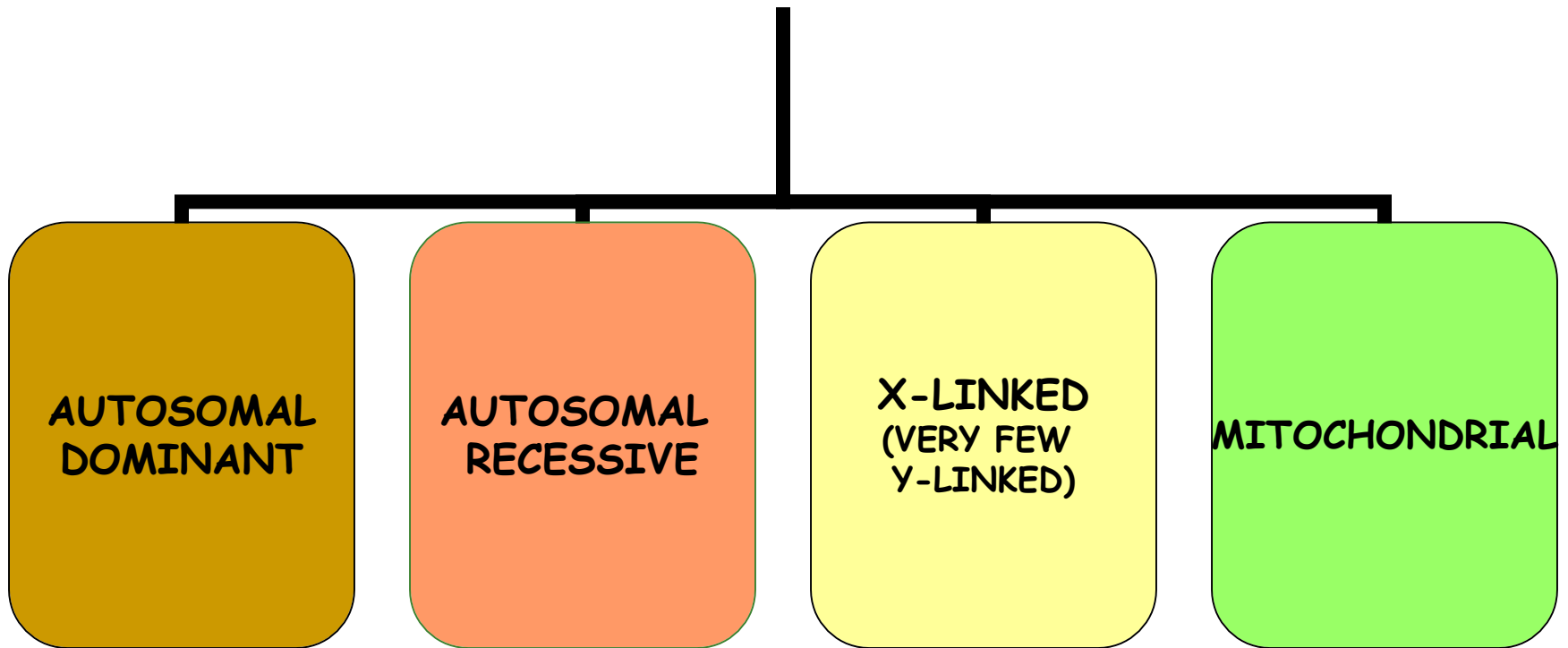

An excellent open access website listing the phenotypes of thousands of single gene disorders is

OMIM Home Page -- Online Mendelian Inheritance in Man

<http://www.ncbi.nlm.nih.gov/omim>

Number of Entries in Online Mendelian Inheritance in Man (OMIM)

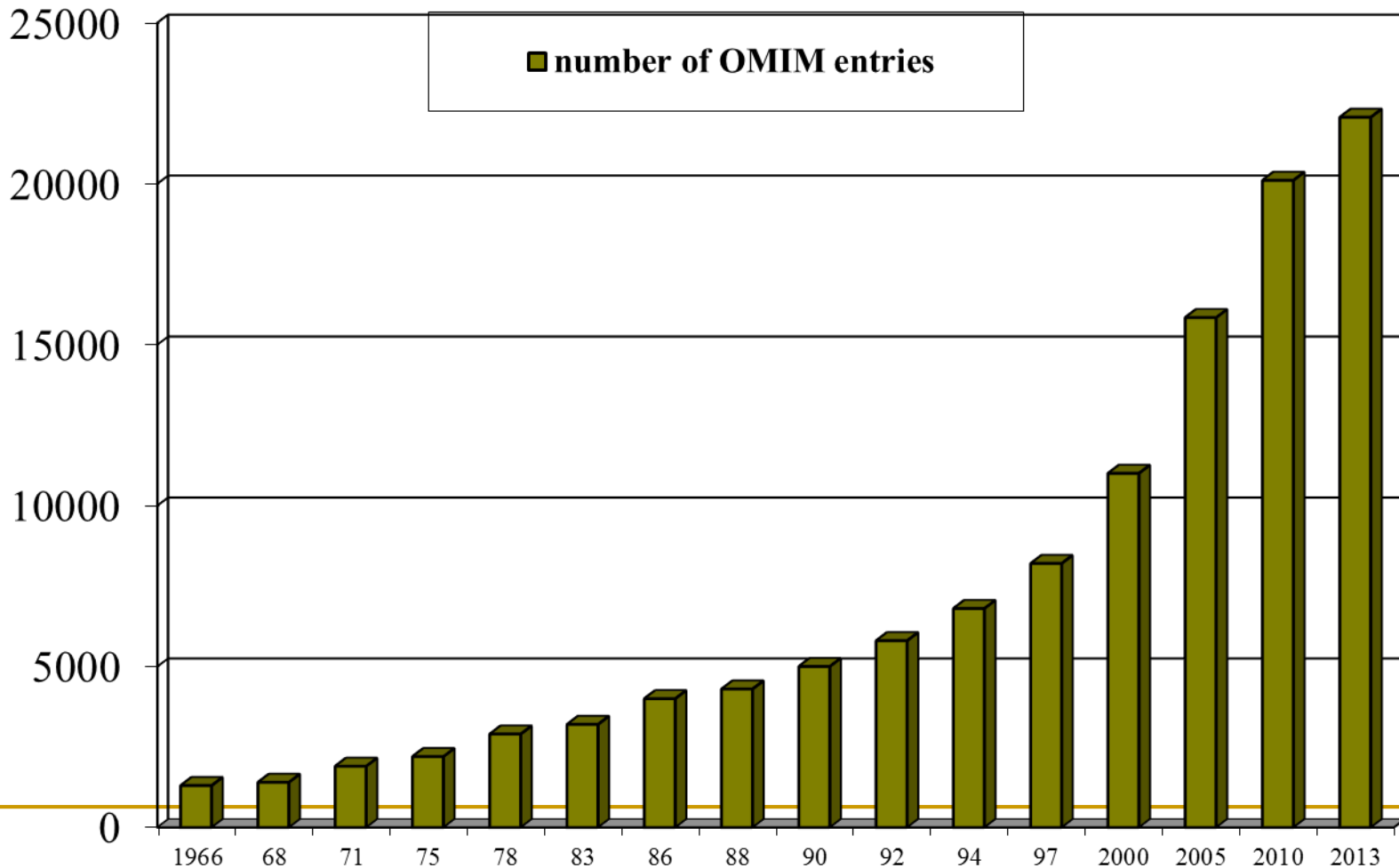

Definitions

(using ABO blood groups locus as example)

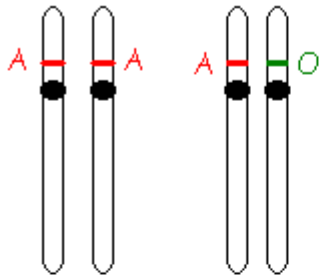

Blood Group A

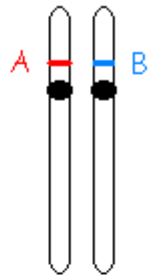

Blood Group AB

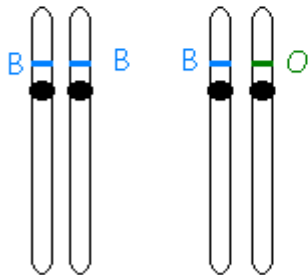

Blood Group B

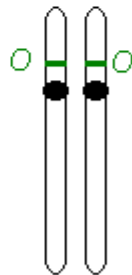

Blood Group O

- **Locus:** position of a certain gene on a certain chromosome, each chromosome of the homologous pair carries an allele
- **Alleles:** Different forms of one gene (A, B and O)
- **Homozygote:** A person who has 2 similar alleles at the locus, for example the alleles AA for blood group A
- **Heterozygote:** A person who has 2 different alleles at the locus, for example the alleles AO for blood group A
- **Dominant** character is expressed in heterozygote (AO)
- **Recessive** character is only expressed in homozygote (OO)
- Codominant: both alleles express themselves (AB)

PEDIGREE DRAWING AND TERMINOLOGY

- A family tree is a shorthand system of recording information about a family. It usually begins with the person through whom the family came to the attention of the investigator. This person is referred to as the *index case*, *proband* or *propositus*, or if female, the *proposita*. The position of the proband in the family tree is indicated by an arrow.

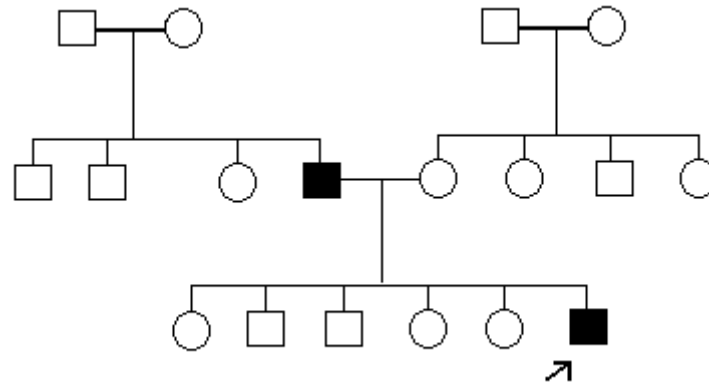



Symbols used in drawing a pedigree

 Normal female

 Normal male

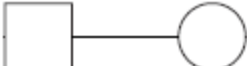
 Unknown sex, normal

 Marriage

 Consanguineous marriage

 Affected male

 Affected female

 Proband or propositus/proposita

 Spontaneous abortion

 Deceased

 Dizygotic twins

 Monozygotic twins

-
- Information about the health of the rest of the family is obtained by asking direct questions about brothers, sisters, parents and maternal and paternal relatives, with the relevant information about the sex of the individual, affection status and relationship to other individuals being carefully recorded in the pedigree chart.
-

Symbols in the pedigree

- Male is given the square symbol
- Female is given the circle symbol
- The line between the male and female symbols means marriage
- Double line means they are consanguineous
- Affecteds are shaded black

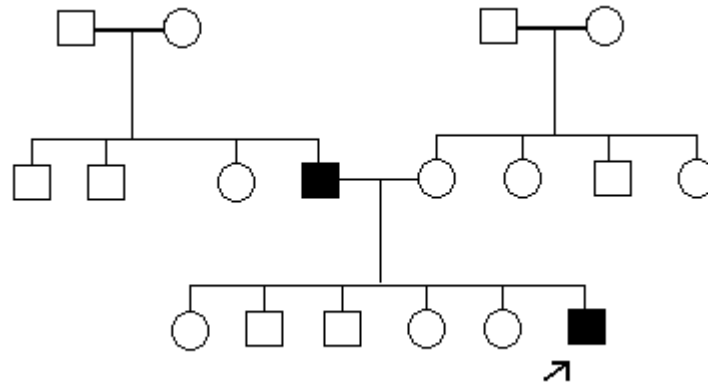

Autosomal dominant inheritance (AD)

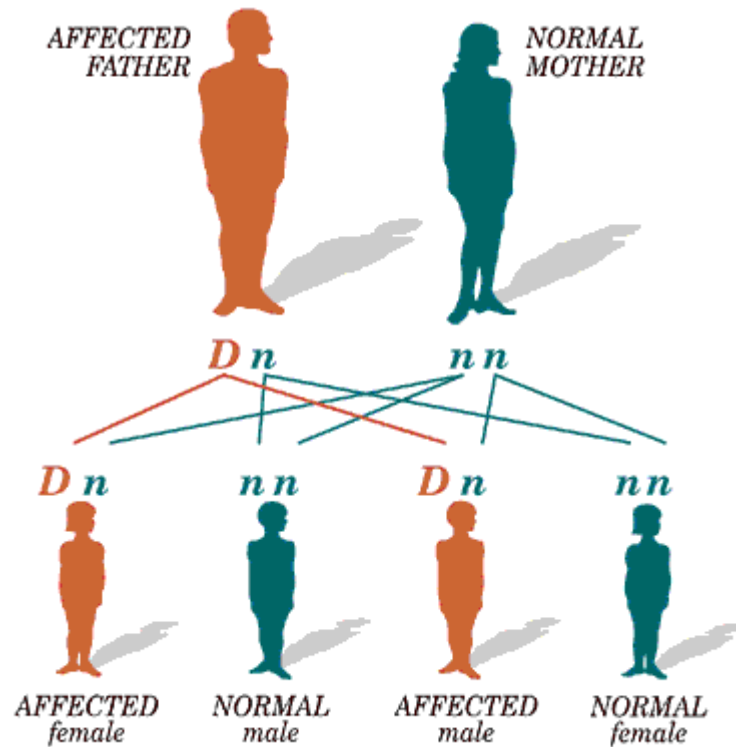

- D is the abnormal gene
- n is the normal gene (or allele)
- Each child of an affected person has a 50% chance of being affected
- Affected persons are usually heterozygous (Dn)
- Both males and females are equally affected

Examples of AD conditions

Neurofibromatosis I showing the café au lait lesions and neurofibroma

Neurofibromatosis

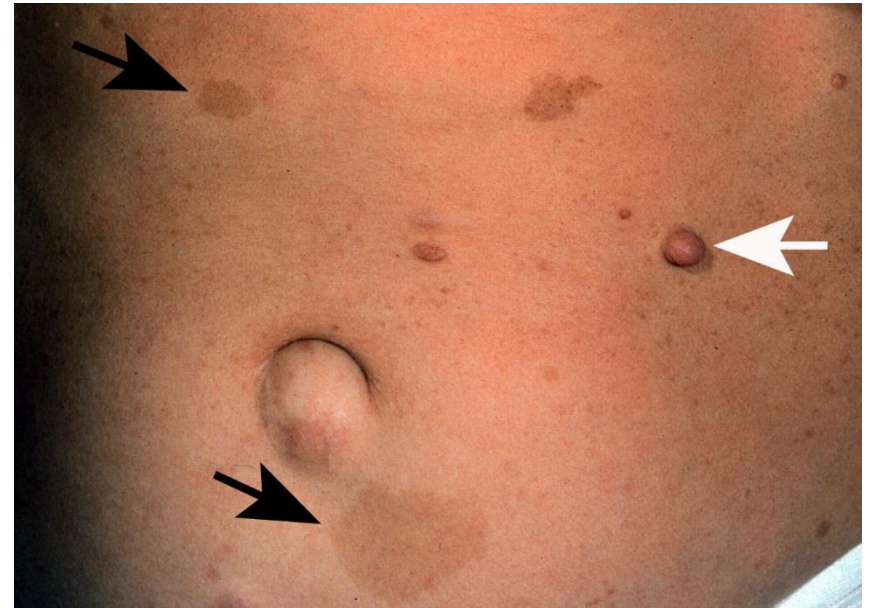

Examples of AD conditions

Achondroplasia: short limbed dwarfism



Pedigrees of AD conditions show vertical transmission of affecteds from one generation to the next

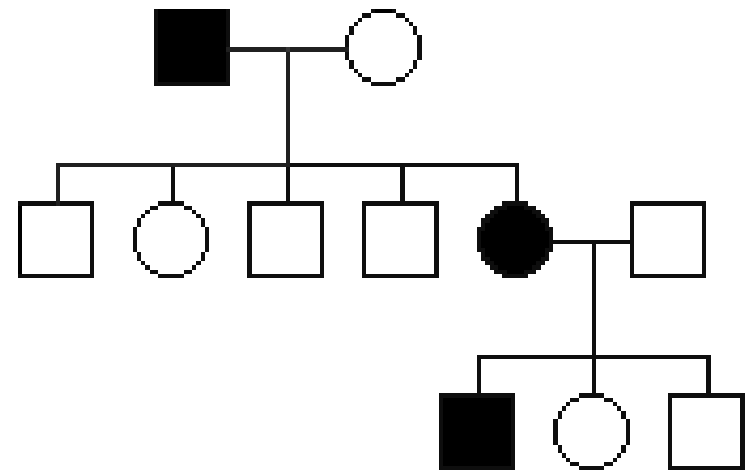
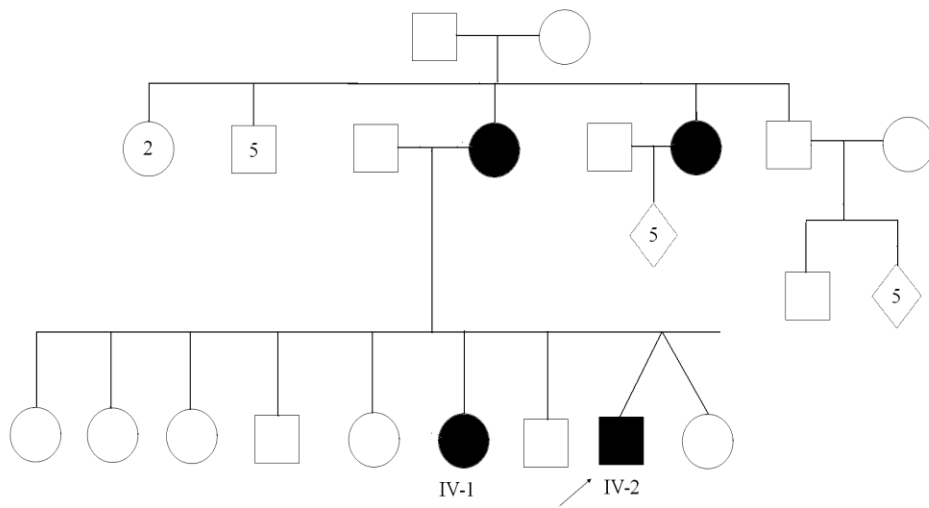

Possible explanations for an affected person who has normal parents

1- New mutation

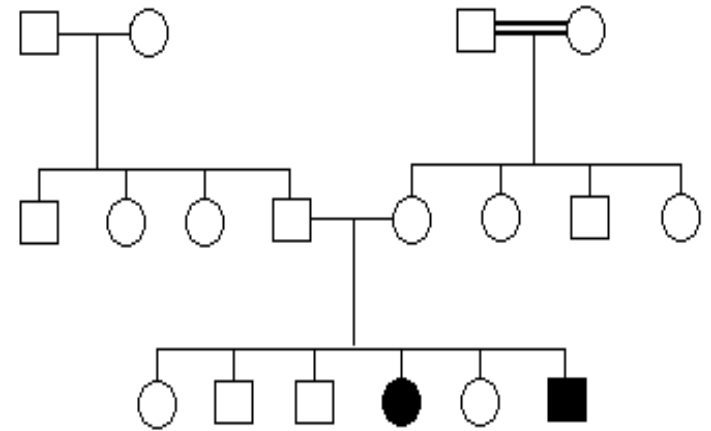
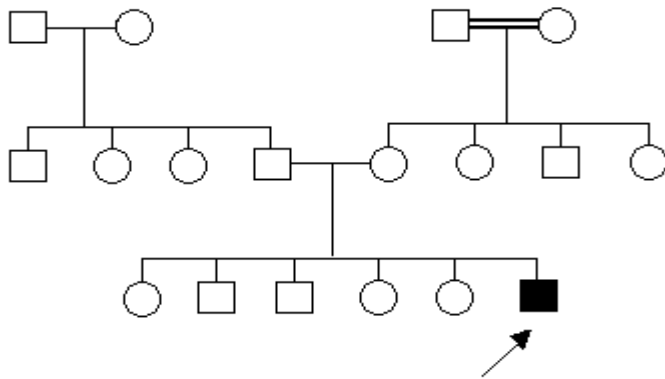

2- Skipped generation could be due to non-penetrance of the gene as in person A

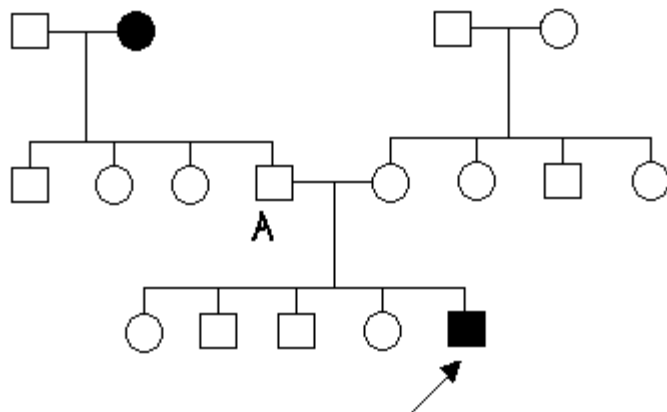

3- More than one affected with normal parents may be due to gonadal mosaicism, that is the gene is present in some cells in the gonad of one parent

Autosomal Recessive Disorders (AR)

- The affected person has 2 abnormal alleles , that is he is a homozygote
 - Heterozygotes are carriers of the abnormal gene and not affected
 - Most of us carry one or two recessive potentially detrimental alleles
 - For common AR disorders such as beta thalassemia, population screening for healthy carriers can identify couples at risk who benefit from prospective genetic counseling
 - This need not involve DNA studies
-

Autosomal recessive inheritance

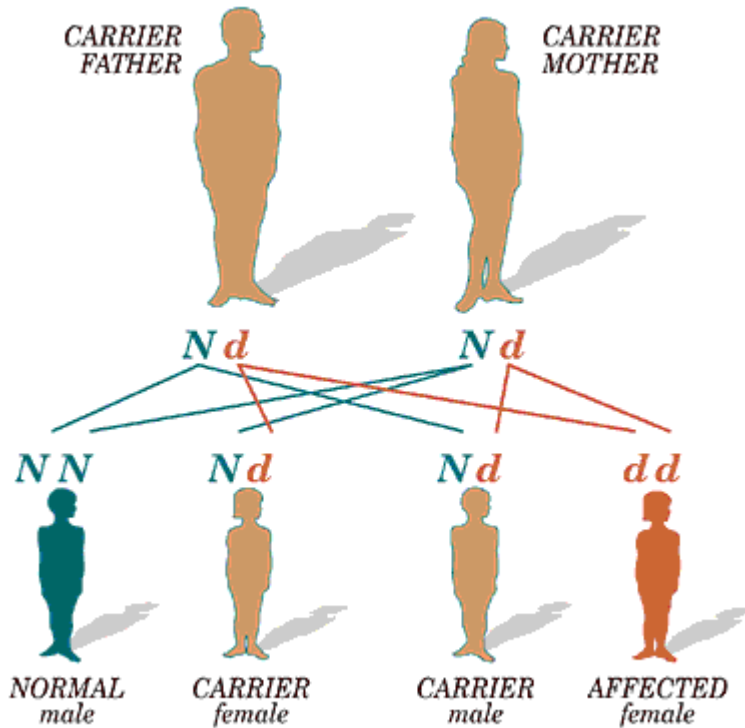

- Both parents of an affected person (dd) are heterozygous for the mutant gene (Nd)
- Each sibling of an affected person has a 25% chance of being affected and a 2/3 chance of being a carrier (2 Nd and one NN among the non-affecteds)

Pedigree of AR conditions shows horizontal transmission which means that the affecteds are in one generation and their parents are not affected with a high probability of being consanguineous

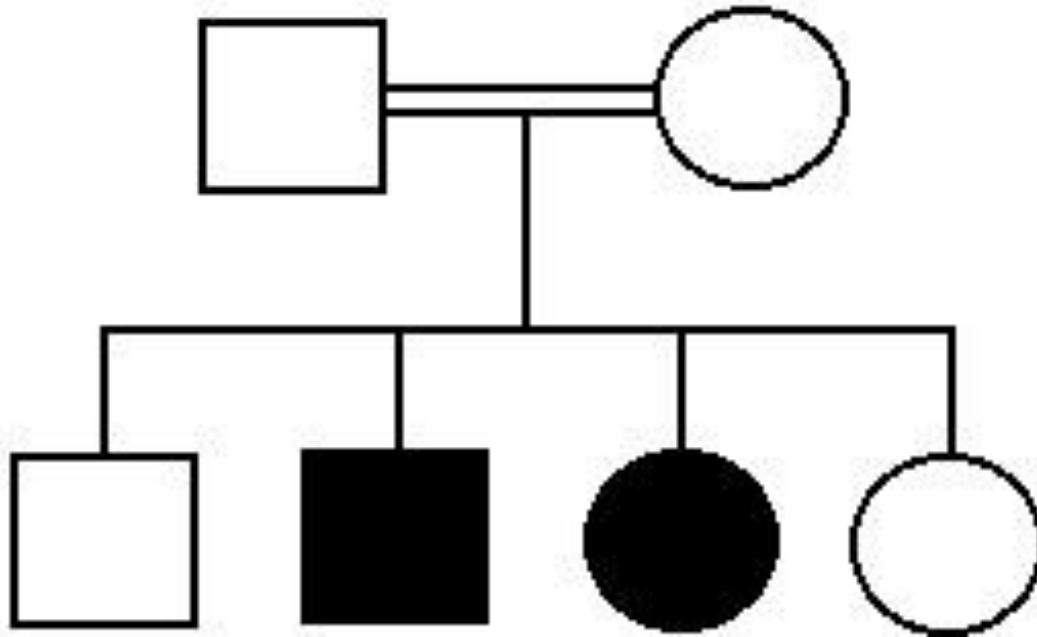

Examples of AR conditions

- Beta thalassemia
 - sickle cell anemia
 - Congenital adrenal hyperplasia
 - Familial Mediterranean fever
 - Cystic fibrosis
 - Phenylketonuria
 - Some cases of deafmutism
-

Genetic heterogeneity:

Means that two different genes cause the same phenotype (clinical picture)

for example: sensorineural deafness (AR)

In this example A and B are different genes causing AR deafmutism. Marriage of two affected persons resulted in non-affected children who are all double heterozygotes

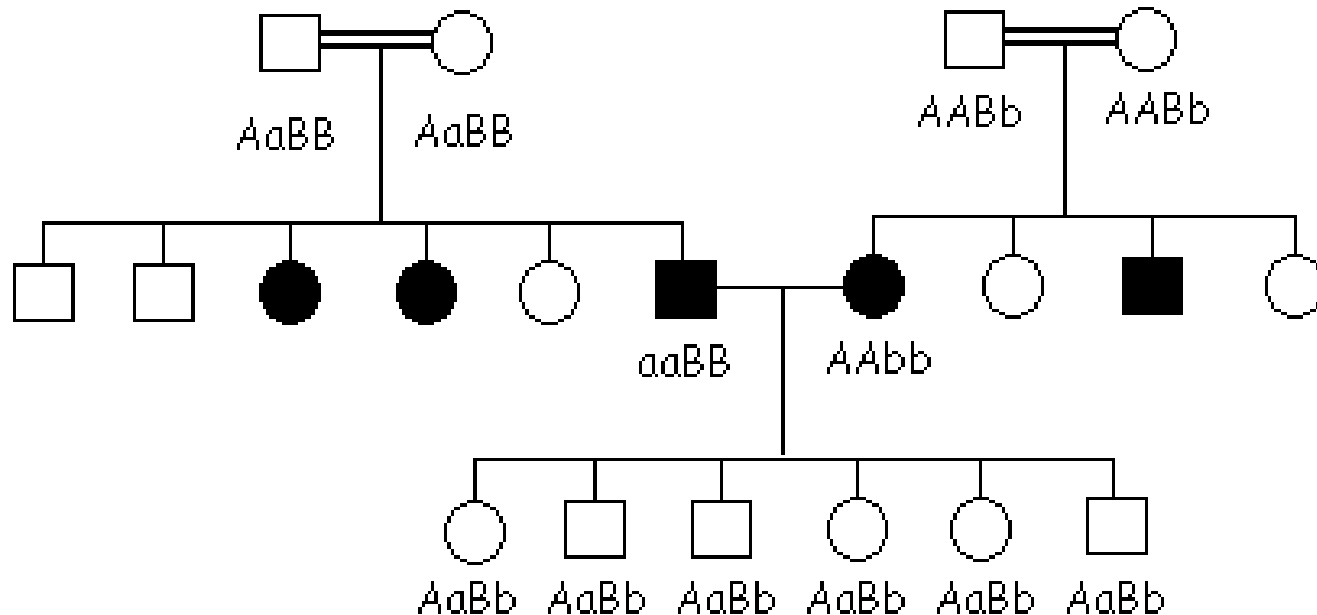

-
- A disorder is said to show genetic heterogeneity if it can be caused by more than one genetic mechanism. Many such disorders are recognized, and counseling can be extremely difficult if the heterogeneity extends to different modes of inheritance. Commonly encountered examples include Charcot-Marie-Tooth disease and retinitis pigmentosa, which can show autosomal dominant, autosomal recessive and X-linked recessive inheritance. Fortunately, progress in molecular genetics is providing solutions to some of these problems.
-

Examples of AR conditions

Bardet Biedl syndrome

Obesity

Mental subnormality

Polydactyly

Retinitis Pigmentosa

Hypogonadism



Examples of AR conditions

Robinow syndrome

showing mesomelia
(short forearms)

Hypogonadism

Short stature

Specific facial features



Examples of AR conditions

Infantile osteopetrosis, which is usually fatal because the excessive bone formation encroaches on bone marrow space leading to pancytopenia. Bone formation around the skull foramina leads to pressure on cranial nerves.

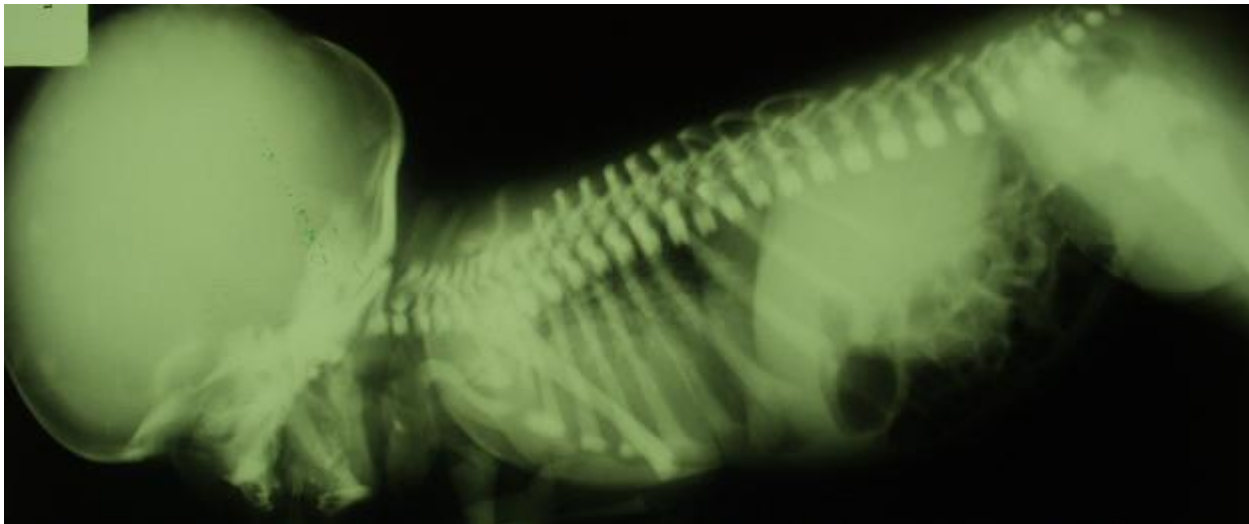

X-linked recessive inheritance

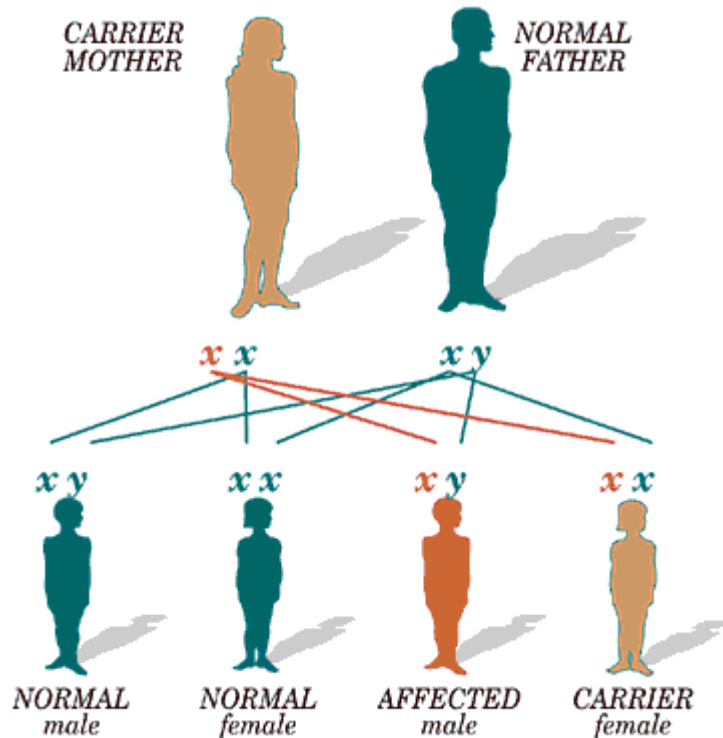

- Heterozygous mothers have a 50% chance to transmit the gene to each son or daughter, the son will be affected (because he has only one X chromosome carrying an abnormal allele, while the daughter will be a carrier)
- Hemizygous affected males transmit the gene to all their daughters but to none of their sons, daughters become carriers

Pedigree of X-linked recessive inheritance shows that affected males are linked through carrier females who are given the symbol of a circle with a dot in the middle

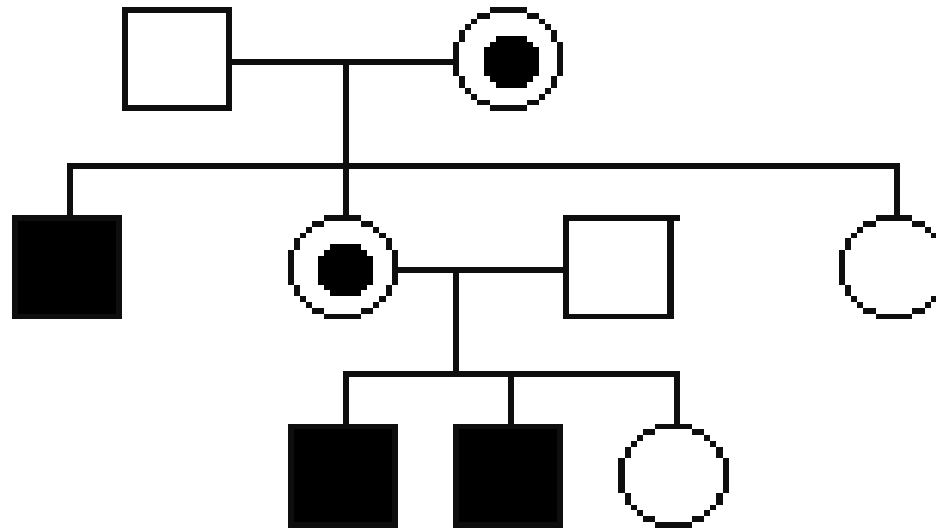

Example: the mother is a carrier for hemophilia and father is not affected

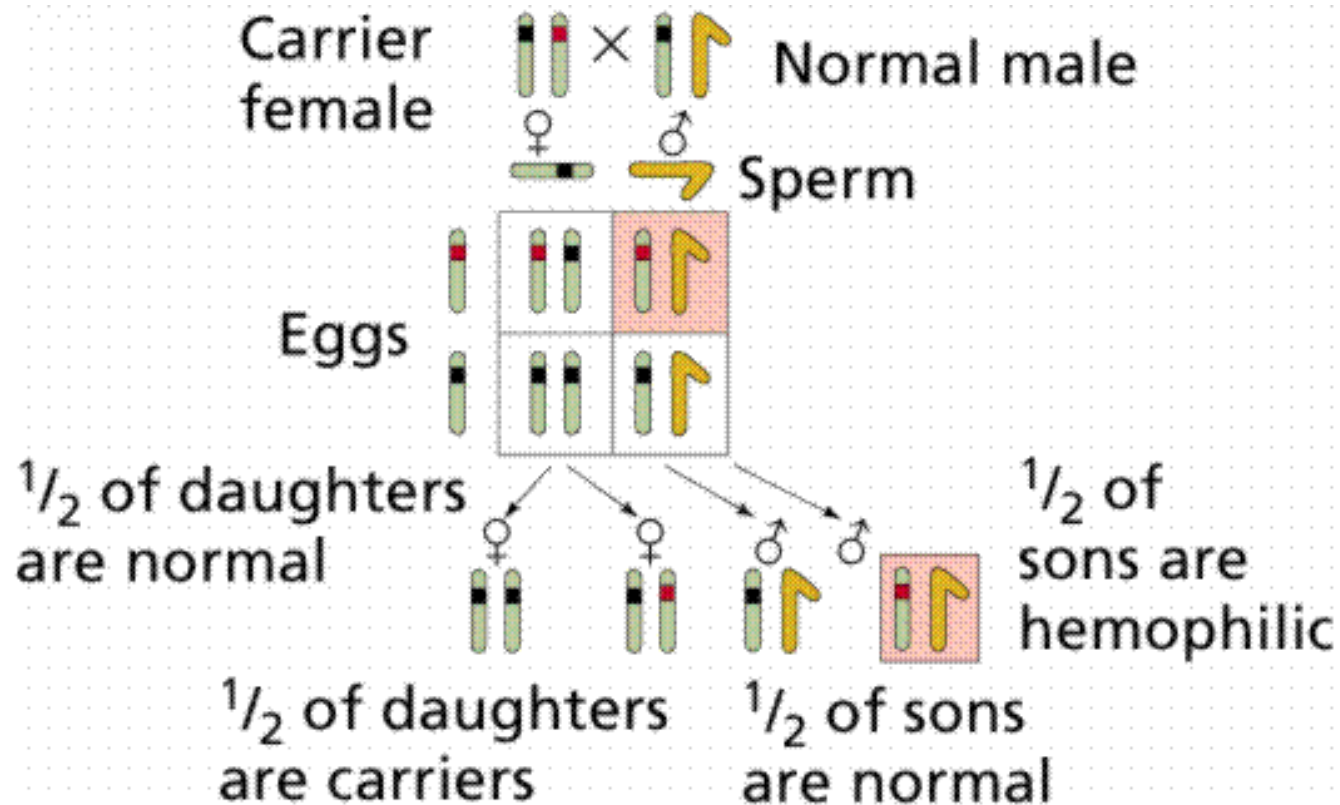

Example: The father is affected by hemophilia and mother is normal (not carrier)

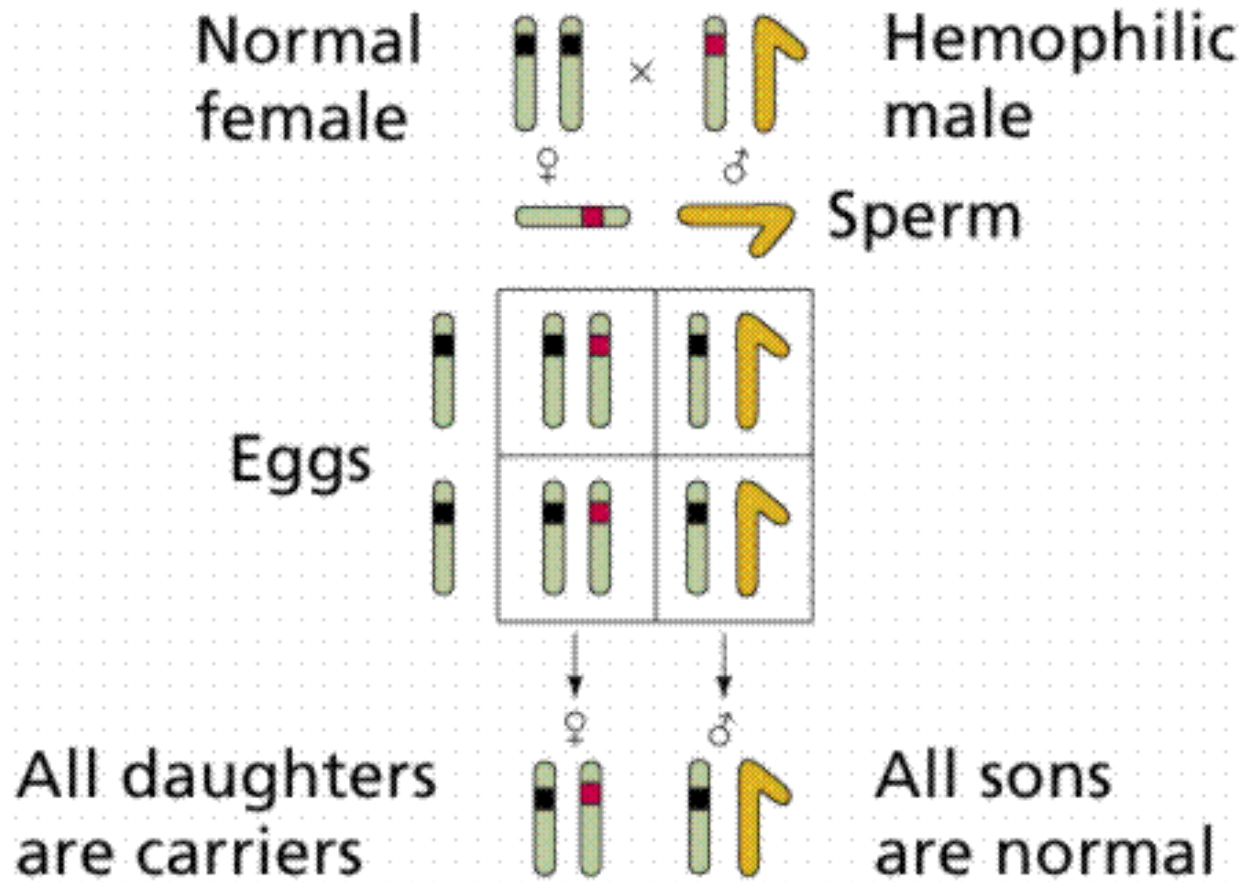

Examples of XR conditions

- Hemophilia
 - G6PD deficiency
 - Duchenne muscular dystrophy
 - Colour blindness
-

Fragile-X syndrome

An X-linked mental retardation (MR) syndrome

- Affects 1:2000 males
- 4-8% of all males with MR have fragile X
- Older boys and adult males usually have a recognizable facial appearance with high forehead, large ears, long face and prominent jaw. After puberty most affected males have large testes (macro-orchidism).



Fragile-X syndrome

- The learning difficulties are moderate to severe and many affected boys show autistic features and/or hyperactive behavior. Speech tends to be halting and repetitive.



X chromosome shows a *fragile site* close to the telomere at the end of the long arm at Xq27.3. A fragile site is a non-staining gap seen with special culture techniques

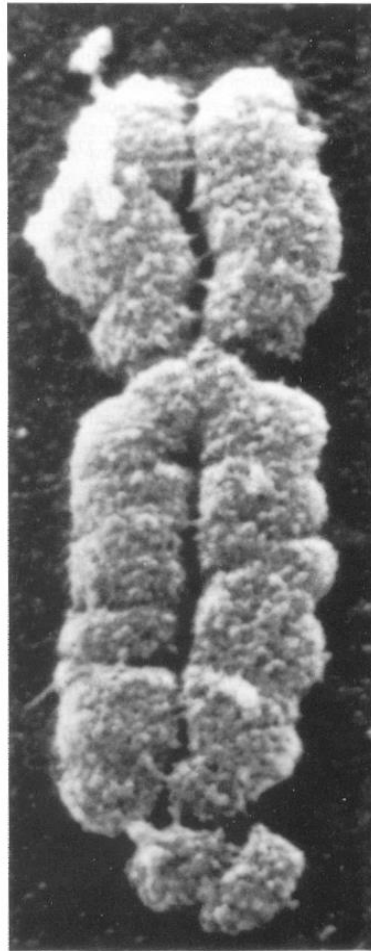

Fragile-X syndrome



- FRAXA gene codes for a protein needed for development and function of cerebral neurons
- The syndrome is caused by unstable mutation: too many *CGG* repeats on the 5' untranslated region causes suppression of expression
- 10-50 copies: normal
- 50-200 copies :premutation , may cause fragile X tremor/ataxia syndrome
- 200-2000 copies causes moderate to severe MR in males
- 200-2000 copies causes mild to moderate MR in 50% of females (**Manifesting heterozygote**)

Expansion of trinucleotide repeat sequences

- In 1991, such expansion of repeats of 3 bases was identified as a mutational mechanism. A number of single-gene disorders have subsequently been shown to be associated with triplet repeat expansions. These are described as *dynamic* mutations because the repeat sequence becomes more unstable as it expands in size. Triplet repeats below a certain length for each disorder are faithfully transmitted in mitosis and meiosis. Above a certain repeat number for each disorder they are more likely to be transmitted unstably, usually with an increase or decrease in repeat number.

X-linked dominant inheritance (XD)

- Pedigree looks similar to AD but there is no male to male transmission

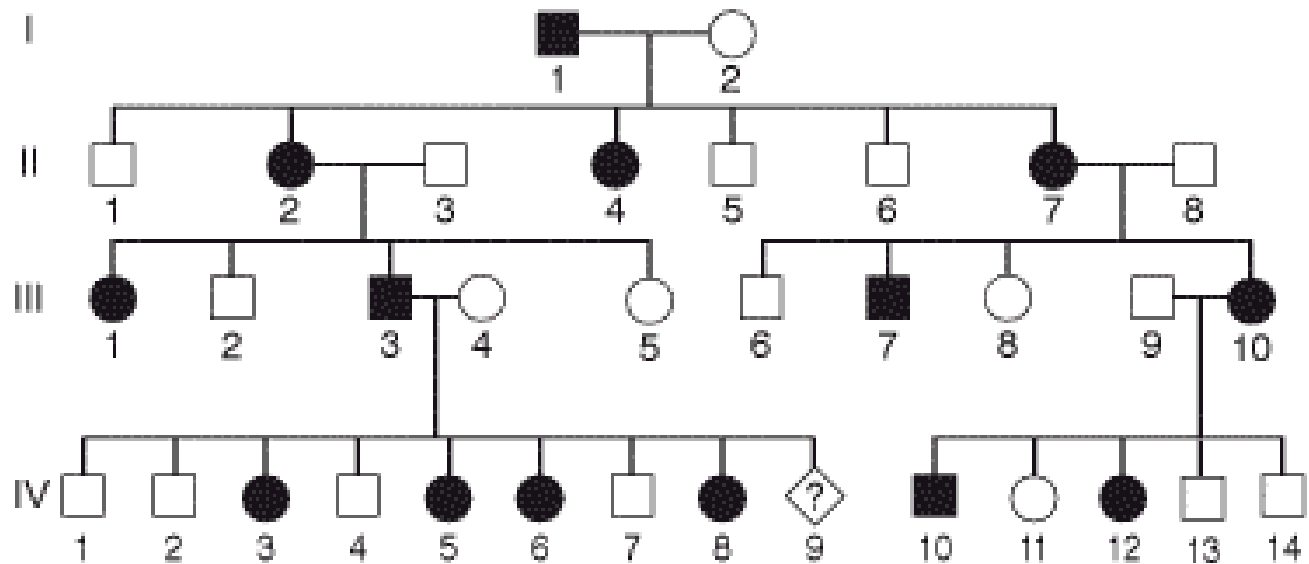

Y-linked

- The trait passes from father to son. An example is hairy ears

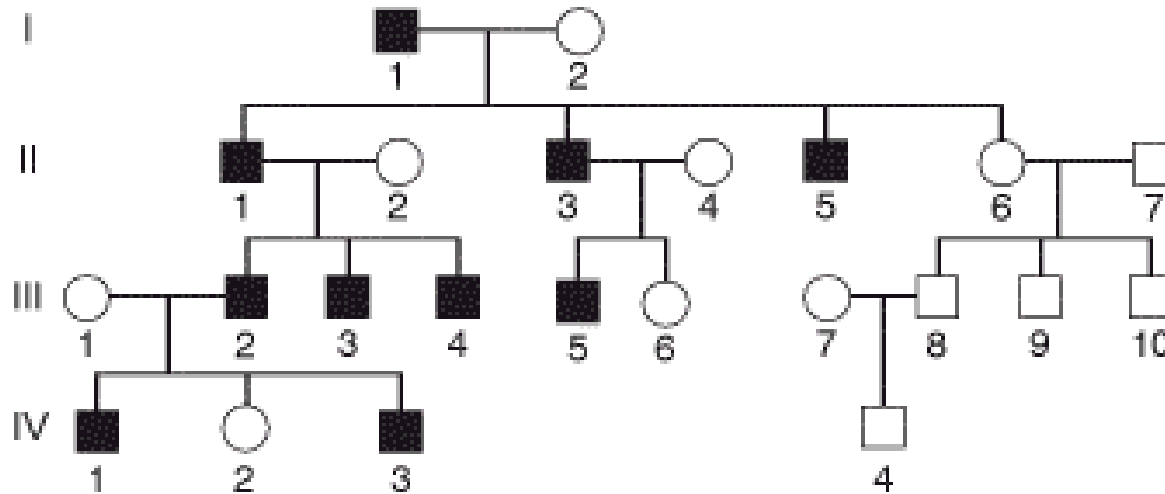

Mitochondrial inheritance

- Matrilineal mode of inheritance: only mother passes mitochondrial DNA to offspring
- Higher spontaneous mutations than nuclear DNA
- affects both males and females , but transmitted only through females
- Has a wide range of severity due to heteroplasmy
- Example: diabetes mellitus with sensorineuronal deafness

Mitochondrial inheritance

- Only affected females can pass the disease to their sons and daughters, affected males have normal offspring

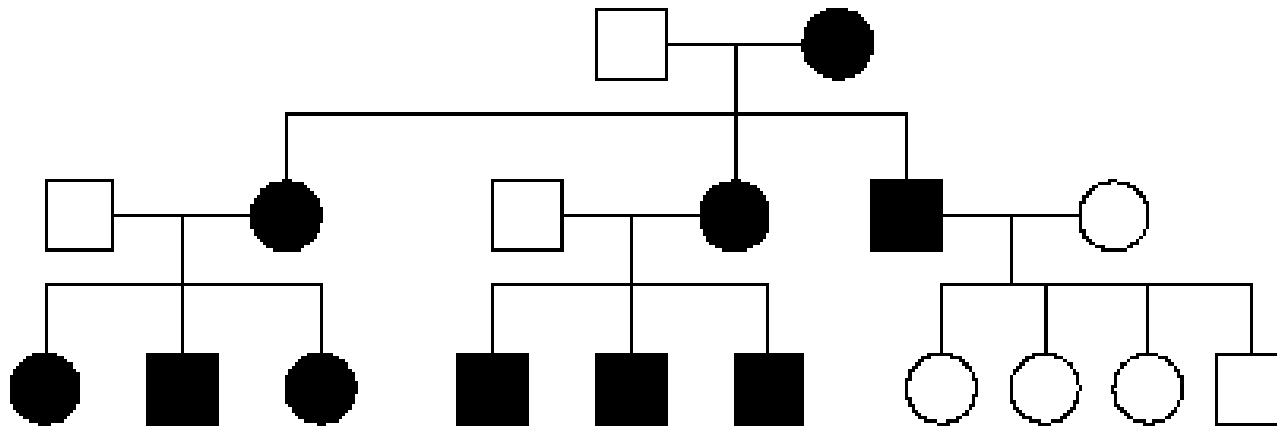

Importance of defining the mode of single gene inheritance

- The risks of recurrence vary with the category of single gene disorder, for example a father affected by AD condition has a risk of 50% of passing the condition to his son and daughter in each pregnancy.
- A couple with a boy affected by an autosomal recessive condition has a 25% chance to have another affected child with each pregnancy.
- Molecular diagnosis are important diagnostic tools for single gene disorders and they can also help in defining the mode of inheritance in cases when the same phenotype is inherited in different ways.

Hereditary disorders that can show different patterns of inheritance

- Congenital cataract AD, AR, XR
 - Microcephaly AD, AR
 - Polycystic kidney disease AD, AR
 - Retinitis pigmentosa AD, AR, XR, M
 - Sensorineural hearing loss AD, AR, XR, M
-

How is recurrence risk calculated?

A first cousin couple where the wife has a brother affected by an AR condition.

Her chance of being a carrier is $2/3$, the husband's chance of being a carrier is $1/4$. Their chance of having an affected child is $2/3 \times 1/4 \times 1/4 = 1/24$

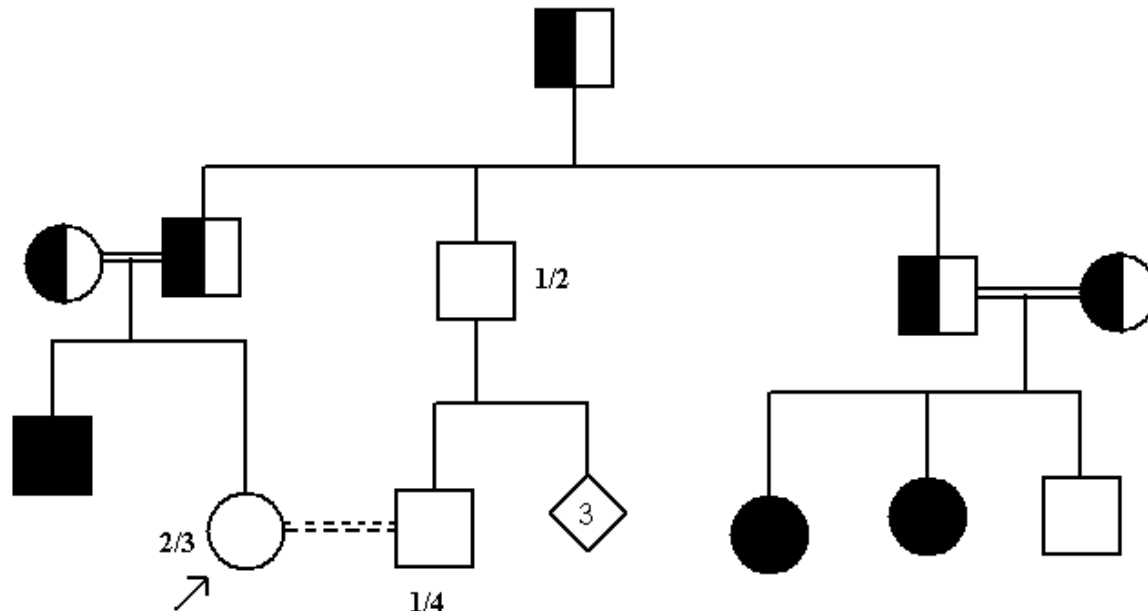

Conclusions

- An affected with autosomal dominant condition usually has one affected parent
- An affected with an autosomal recessive condition may have affected brothers and sisters and normal parents who are consanguineous
- Boys are affected by X-linked recessive condition when they get the abnormal allele from their carrier mother
- DNA tests can diagnose a large number of single gene disorders